 A320 <small>SIMULATOR</small> FLIGHT CREW OPERATING MANUAL	APU	1.49.00	P 1
	CONTENTS	SEQ 001	REV 23

49.00 CONTENTS

49.10 DESCRIPTION

- GENERAL 1
- MAIN COMPONENTS 2

49.20 CONTROLS AND INDICATORS

- OVERHEAD PANEL 1
- EXTERNAL CONTROLS 3
- ECAM APU PAGE 4
- WARNINGS AND CAUTIONS 6
- MEMO DISPLAY 6

49.30 ELECTRICAL SUPPLY

GENERAL

The Auxiliary Power Unit (APU) is a self-contained unit that makes the aircraft independent of external pneumatic and electrical power supplies.

On the ground

- It supplies bleed air for starting the engines and for the air conditioning system.
- It supplies electrical power to the electrical system.

During takeoff

- It supplies bleed air for air conditioning, thus avoiding a reduction in engine thrust caused by the use of engine bleed air for this purpose when optimum aircraft performance is required.

In flight

- It backs up the electrical system.
- It backs up the air conditioning.
- It can be used to start the engines.

The APU may obtain power for starting from the aircraft's batteries or normal electrical system, or from ground service.

R APU starting is permitted throughout the normal flight envelope (refer to FCOM 3.01.49). The ECAM displays APU parameters.

FOR INFO

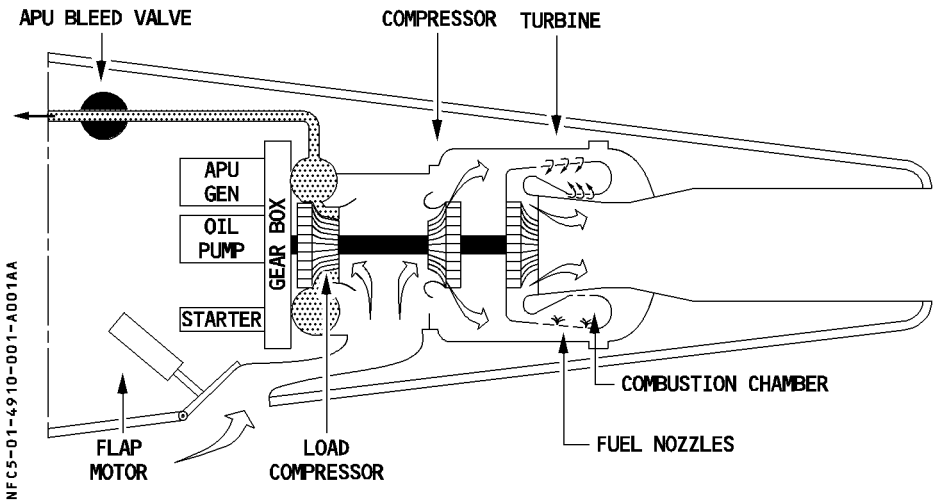

	APU	1.49.10	P 2
	DESCRIPTION	SEQ 001	REV 23

MAIN COMPONENTS

APU ENGINE

The basic element of the APU is a single-shaft gas turbine that delivers mechanical shaft power for driving the accessory gearbox (electrical generator, starter, etc.) and produces bleed air (engine starting and pneumatic supply).

ELECTRONIC CONTROL BOX

The Electronic Control Box (ECB) is a full-authority digital electronic controller that performs the bulk of the APU system logic for all modes of engine operation, such as :

- Sequences the start and monitors it.
- Monitors speed and temperature.
- Monitors bleed air.
- Sequences the shutdown.
- Controls the automatic shutdown.

AIR INTAKE SYSTEM

The air intake and an electrically operated flap allow external air to reach the compressor inlet.

STARTER

The ECB controls the electric starter. The starter engages if the air intake is fully open and the MASTER SW and the START pushbutton are ON.

FUEL SYSTEM

The left fuel feed line supplies the APU.

The required pressure is normally available from tank pumps.

If pressure is not available (batteries only or pumps off) the APU FUEL PUMP starts automatically.

The ECB controls the fuel flow.

OIL SYSTEM

The APU has an integral independent lubrication system (for lubrication and cooling).

INLET GUIDE VANES (IGV)

The IGVs control bleed air flow, and a fuel-pressure-powered actuator positions the IGVs. The ECB controls the actuator in response to aircraft demand.

 AIRBUS TRAINING A320 SIMULATOR FLIGHT CREW OPERATING MANUAL	APU	1.49.10	P 3
	DESCRIPTION	SEQ 110	REV 27

AIR BLEED SYSTEM

The air bleed system is fully automatic.

The APU speed is always 100 % except for air conditioning, the APU speed is 99 % if the ambient temperature is above – 18°C or if ambient temperature is below 35°C.

CONTROLS

The flight crew uses the controls on the APU panel for routine shutdown. For emergency shutdown :

- the flight crew can push the APU FIRE handle, or
- the ground crew can push the APU SHUT OFF pushbutton on the interphone panel under the nose fuselage.

GROUND OPERATION SAFETY DEVICES

The APU may run without cockpit crew supervision when the aircraft is on the ground. In case of fire in the APU compartment :

- APU fire warnings operate in the cockpit.
- A horn in the nose gear bay sounds.
- The AVAIL light goes out.
- The FAULT light in the MASTER SW lights up.
- The APU shuts down.
- The APU fire extinguisher discharges.



OVERHEAD PANEL

NF C5-01-4920-001-A 110AA

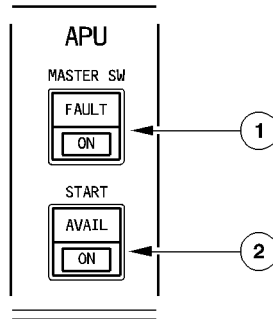

① MASTER SW pushbutton

This switch controls the electric power supply for APU operation, and its protective features. It also controls the starting and shutdown sequences.

ON : The blue ON light comes on.

Electric power goes to the APU system ; the ECB performs a power-up test.

The APU air intake flap opens.

The APU fuel isolation valve opens.

If no fuel tank pump is running, the APU fuel pump operates.

If the aircraft has ground power or main generator power, the APU page appears on the ECAM display.

OFF : Manual shutdown sequence.

– The ON light on the MASTER SW pushbutton, and the AVAIL light on the START pushbutton, go off.

– If the aircraft was using APU bleed air, the APU keeps running for a cooling period of 60 seconds.

– At 7 %, the air inlet flap closes.

FAULT It : This amber light comes on, and a caution appears on the ECAM, when an automatic APU shutdown occurs, which happens in case of :

Fire (on ground only)

Reverse flow

Air inlet flap not open

Low oil pressure

Overspeed

High oil temperature

No acceleration

DC power loss. (BAT OFF when aircraft on batteries only)

No speed

ECB failure

EGT overtemperature

Loss of overspeed protection

No flame

Oil system shutdown

Underspeed

Inlet overheat

Clogged oil filter

Loss of EGT thermocouples

R

 AIRBUS TRAINING A320 SIMULATOR FLIGHT CREW OPERATING MANUAL	APU	1.49.20	P 2
	CONTROLS AND INDICATORS	SEQ 110	REV 28

② START pb sw

- R ON** : Blue ON light comes on.
- When the flap is completely open, the starter is energized.
 - 1.5 second after the starter is energized, the ignition turns on.
 - When N = 60 %. The APU starter is de-energized. The ignition is turned off.
 - 2 seconds after N reached 95 %, or when N is above 99.5 % :
 The ON light on the START pushbutton goes out.
 The APU may now supply bleed air and electrical power to the aircraft systems.
 - 10 seconds later, the APU page disappears from the ECAM display.
- AVAIL It** : This green light comes on when N is above 99.5 % or 2 seconds after N reaches 95 %.



EXTERNAL CONTROLS

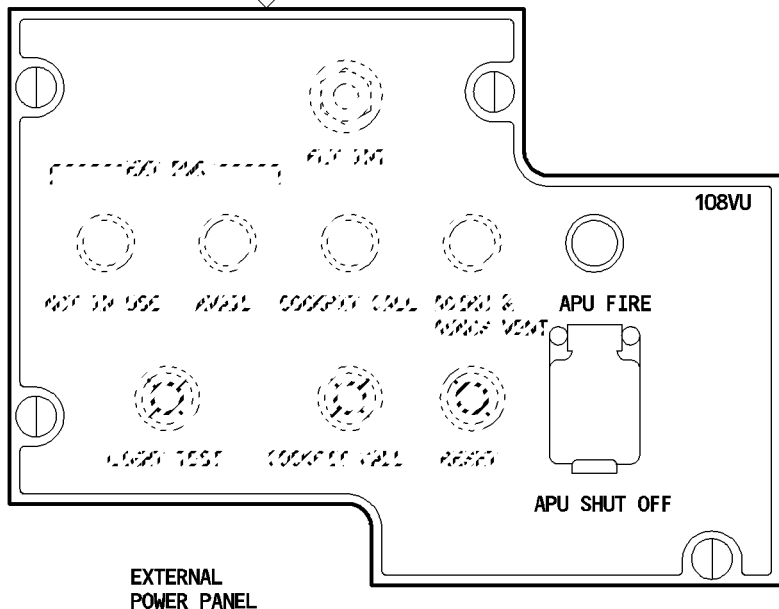
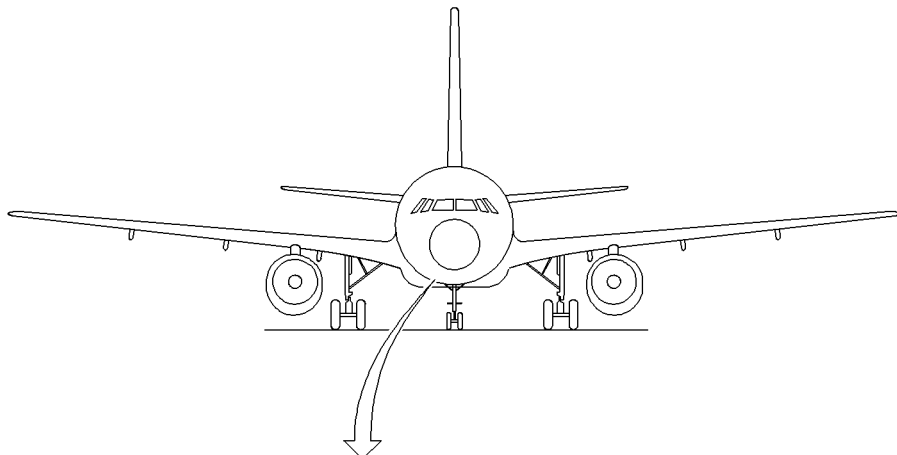

NFC5-01-4920-003-A001AB



ECAM APU PAGE

NFCS-01-4920-004-A110AA

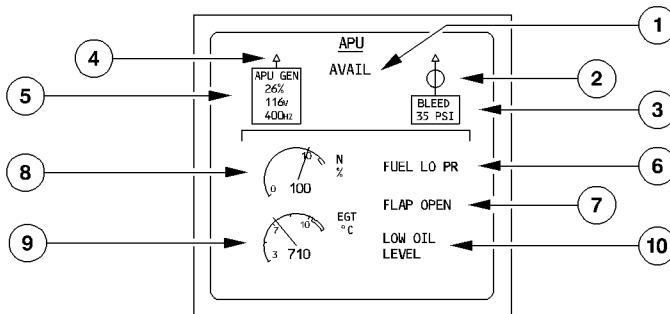

① AVAIL

Displayed in green when APU N is above 95 %.

② APU bleed valve position

- ⊕ : Valve fully open (green)
Valve fully open (amber) if APU bleed switch is off
- ⊖ : Valve fully closed (green)
Valve fully closed (amber) if APU bleed ON

③ APU bleed air pressure

This box displays the relative bleed air pressure in green. It shows an amber XX when the ADIRS2 is not available or selected OFF or the data from the ECB invalid or not transmitted.

④ APU GEN line contactor indication

Displayed in green when the APU GEN line contactor is closed.

⑤ APU GEN parameters

Identical to the APU GEN parameters on the ELEC page.

⑥ FUEL LO PR

Displayed in amber if APU fuel pressure gets low.

⑦ FLAP OPEN

– Displayed in green when APU air intake flap is fully open (MASTER SW ON).



8 APU N

- Displays APU speed in green.
- Becomes amber when $N \geq 102\%$.
- Becomes red when $N \geq 107\%$.

9 APU EGT

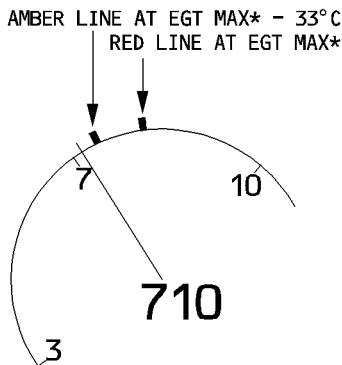

NFC5-01-4920-005-A110AA

- Displays APU EGT in green.
 - Becomes amber when $EGT \geq EGT\ max^* - 33^\circ C$.
 - Becomes red when $EGT \geq EGT\ max^*$ (automatic shutdown begins).
- * ECB calculates EGT max and transmits it to ECAM. It is a function of N during start and a function of ambient temperature when the APU is running.
Maximum EGT during start : 1090°C.
Maximum EGT with APU running : 675°C.

10 LOW OIL LEVEL

Advisory : displayed if the ECB detects a low APU oil level when the aircraft is on the ground and the APU is not running.



WARNINGS AND CAUTIONS

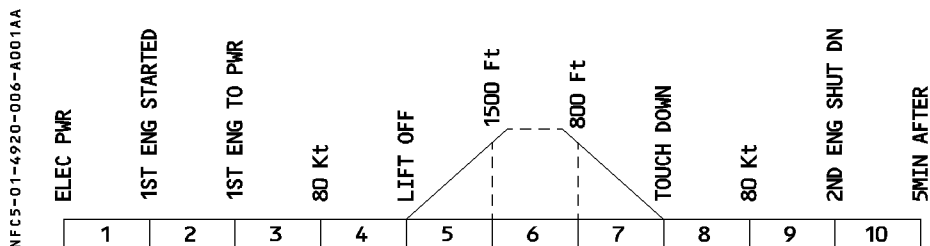

E/WD : FAILURE TITLE conditions	AURAL WARNING	MASTER LIGHT	SD PAGE CALLED	LOCAL WARNING	FLT PHASE INHIB
AUTO SHUT DOWN automatic shut down of APU for a reason other than a fire.					
EMER SHUT DOWN use of APU shut off pushbutton on external power panel or APU FIRE pushbutton pushed. In case of APU fire on ground, the APU FIRE warning is triggered.	SINGLE CHIME	MASTER CAUT	APU	APU MASTER SW FAULT It	3, 4, 5 7, 8

MEMO DISPLAY

- APU AVAIL appears in green when APU N is above 95 %.

BUS EQUIPMENT LIST

	NORM			EMER ELEC		
	AC	DC	DC BAT	AC ESS	DC ESS	HOT
ECB SUPPLY			X			
STARTER MOTOR			X			

Note : When the system is in electrical emergency configuration, battery contactors automatically close for a maximum of 3 minutes, when the APU MASTER SW is ON.

When the aircraft is in flight, and when the system is in electrical emergency configuration, the APU start is inhibited for 45 seconds.